



Turn-Dex



Answer Engineering

COMPACT[®]

AUTOMATION PRODUCTS LLC

An **IMC** Company

Turn-Dex: Table of Contents

Turn-Dex

Turn-Dex 1-1/4" Bore..... pg. 2
How to Order..... pg. 3
Dimensional Data..... pg. 4

Turn-Dex 2-1/2" Bore..... pg. 5
How to Order..... pg. 6
Dimensional Data..... pg. 7

Adjustable Stroke Control (ASC)..... pg. 8

Turn-Dex Options

Flange Mount..... pg. 9
Side Angle Mounts..... pg. 10
Side Mounts..... pg. 11
Thrust Protection..... pg. 12
Cap Sensor Systems..... pg. 13
Trantorque®..... pg. 14
Hub Adapter..... pg. 15

Notes..... pg. 16

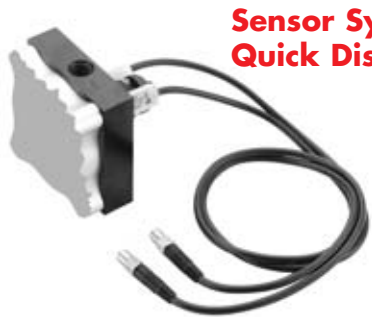

Sensor System with 8mm Quick Disconnect Pg. 13



Sensor System with 9 ft. Leads Pg. 13



Turn-Dex Actuator with Adjustable Stroke Control (std) Pg. 2

Turn-Dex 1-1/4" Bore

ROTARY VANE ACTUATORS

with integral unidirectional clutch:

- 6 base models with torque outputs from 13 in. lbs. to 60 in. lbs.
- Clockwise or Counterclockwise stepped rotations.
- Adjustable Stroke Control is standard.

Turn-Dex Stepper Indexer:

- Highly repeatable (+/- 1/2 degree).
- Provide instantaneous and continuous full torque.
- Produce more torque in less space.
- Eliminates gears and pivot points that wear, break or strip.
- Patented Urethane seals for:
 - Long cycle life and Non-lube service.
 - Actual applications with 25 million cycles and more.
- 100s of standard options and modifications.

Just imagine... How Answer Engineering can work for you!



TURN-DEX ACTUATOR WITH ADJUSTABLE STROKE CONTROL (STD) SHOWN WITH OPTION 801 (SIDE MOUNTS POS. 2 & 6)

Torque Chart (IN LBS.)			
180° and 270° Rotations ²			
Actuator Model	Actuator Torque at		
	100 PSI	80 PSI	60 PSI
321	13	10	7
323			
341	32	25	19
343			

Torque Chart (IN LBS.)			
90° Rotations ²			
Actuator Model	Actuator Torque at		
	100 PSI	80 PSI	60 PSI
322	25	20	15
342	60	48	36

SPECIFICATIONS

Unit Materials

Stator/Rotor SealsUrethane
 Shaft/Tube SealsBuna'
 Shaft.....1144 G&P Steel
 Body.....Anodized Alum.
 BearingsFull Comp. Needle

Miscellaneous

Inlets1/8 NPT
 Min. Pressure35 psi
 Max. Pressure200 psi
 Cylinder Bore.....1-1/4"

Shaft Load Capacities

Max. Side Load125 lbs.
 Max. End Load.....10 lbs.

Temperature Range

-20°F to 180°F. Consult factory for higher temperature.

Filtration

Air 25-50 microns

Clutch

Type.....Roller, lock in one direction, free overrun in other direction.
 Max. Torque Rating...143 in. lbs.

Cycle Rates³

Max. non-lubed rate:
 Double Vane40 cpm
 Single Vane20 cpm

Max. lubed rate:
 Consult Factory

Rotary Motion Backlash

All models.....0 degree

Leak Rates

Air 4 cfm or less@100 psi

1. Viton Optional
2. All rotations are nominal +4/-0 actual
3. Cycle = Start position to end of rotation and returning to the start position.
 Stroke = 1/2 cycle

Capacity per Stroke ³ (IN ³)				
Actuator Model	270° Rotation ²		90° Rotation ²	
	321	0.99	322	0.84
341	1.99	342	1.68	

Weights (OZs)				
Actuator Model	270° Rotation ²		90° Rotation ²	
	321	10	322	10
341	14	342	14	

How to Order: Turn-Dex 1-1/4" Bore

DRIVE
MODEL DIRECTION OPTIONS OPTIONS
341 - 1 - A02 - XXX
1 2 3 3

1

Model			
Model	Bore	Torque	Rotation
321	1-1/4"	13	270
322	1-1/4"	25	90
323	1-1/4"	13	180
341	1-1/4"	32	270
342	1-1/4"	60	90
343	1-1/4"	32	180

2

Drive Direction	
Based on shaft end view and inlets at 12 O'Clock	
1	Clockwise
2	Counter-clockwise

3

Options	
Additional options available on pg. 9	
Option #	Description
000	No Options
100	Front Flange
101	Rear Flange
200	Side Angle Brackets, Mounting Surface 3 & 7
201	Side Angle Brackets, Mounting Surface 2 & 6
202	Side Angle Brackets, Mounting Surface 4 & 8
203	Side Angle Brackets, Mounting Surface 1 & 5
800	Side Mounts, Sides 1 & 5
801	Side Mounts, Sides 2 & 6
803	Side Mounts, Sides 4 & 8
804	Side Mounts, Sides 2, 4, 6 & 8
806	Side Mounts, Sides 6 & 8
807	Side Mounts, Sides 2 & 4
810	No Bottom Mounts
Cap Sensor Options (See pg. 13)	
A00	Sensor System – No Sensors
A05	Sensor System – 2 Sourcing Sensors
A08	Sensor System – 2 Sinking Sensors
A02	Sensor System – 2 Reed Sensors
A25	Sensor System – 2 Sourcing Sensors*
A28	Sensor System – 2 Sinking Sensors*
A22	Sensor System – 2 Reed Sensors*

*NOTE: See page 13 for Lead Type variation

Dimensional Data: Turn-Dex 1-1/4" Bore

Basic Dimensions

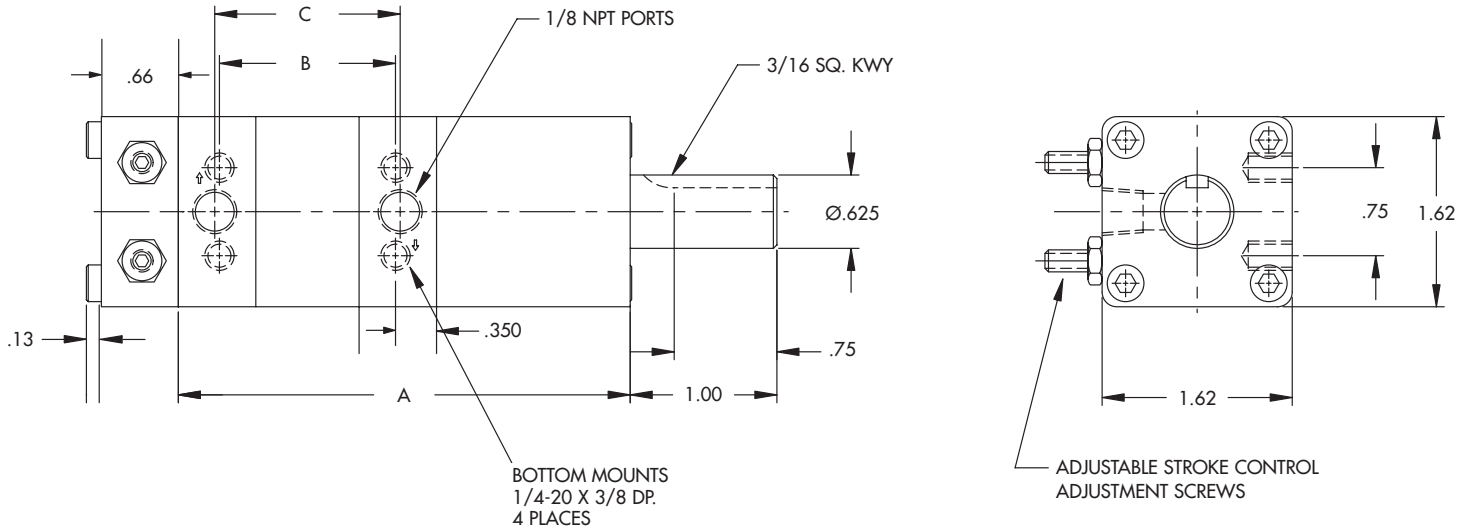

Dimensional Specifications			
Actuator	A	B	C
321	3.84	1.50	1.57
322	3.84	1.50	1.57
323	3.84	1.50	1.57
341	4.84	2.50	2.57
342	4.84	2.50	2.57
343	4.84	2.50	2.57

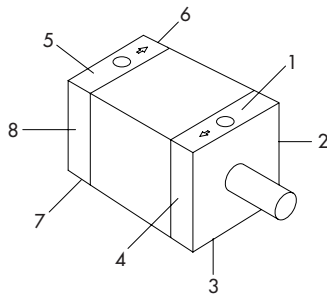

Port & Mounting Position References

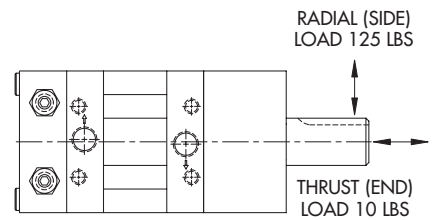

Shaft Load Capacity

Turn-Dex 2-1/2" Bore

ROTARY VANE ACTUATORS

with integral unidirectional clutch:

- 10 base models with torque outputs from 87 in. lbs. to 350 in. lbs.
- Clockwise or Counterclockwise stepped rotations.
- Adjustable Stroke Control is standard.

Turn-Dex Stepper Indexer:

- Highly repeatable (+/- 1/2 degree).
- Provide instantaneous and continuous full torque.
- Produce more torque in less space.
- Eliminates gears and pivotpoints that wear, break or strip.
- Patented Urethane seals for:
 - Long cycle life and Non-lube service.
 - Actual applications with 25 million cycles and more.
- 100s of standard options and modifications.

Just imagine... How Answer Engineering can work for you!



**TURN-DEX ACTUATOR
(NO OPTIONS)**

Torque Chart (IN. LBS.)			
180° and 270° Rotations ²			
Actuator Model	Actuator Torque at		
	100 PSI	80 PSI	60 PSI
411 413	87	70	52
421 423	175	140	105
431 433	350	280	210

Torque Chart (IN. LBS.)			
45° AND 90° Rotations ²			
Actuator Model	Actuator Torque at		
	100 PSI	80 PSI	60 PSI
412 414	175	140	105
422 424	350	280	210

SPECIFICATIONS

Unit Materials

Stator/Rotor Seals...Urethane
 Shaft/Tube SealsBuna¹
 Shaft1 1/4 G&P steel
 Body.....Anodized Alum.
 Bearings ...Full Comp. Needle

Miscellaneous

Inlets.....1/4 NPT
 Min. Pressure35 psi
 Max. Pressure200 psi⁴
 Cylinder Bore2-1/2"

Shaft Load Capacities

Max. Side Load.....250 lbs.
 Max. End Load.....25 lbs.

Temperature Range

-20°F to 180°F. Consult factory for higher temperature.

Filtration

Air25-50 microns

Clutch

Type.....Roller, lock in one direction, free overrun in other direction
 Max. Torque Rating...412 in. lbs.

Cycle Rates³

Max. non-lubed rate:
 Double Vane40 cpm
 Single Vane20 cpm

Max. lubed rate:
 Consult Factory

Rotary Motion Backlash

All models0 degree

Leak Rates

Air.....4 cfm or less@100 psi

1. Viton Optional
2. All rotations are nominal +4/-0 actual
3. Cycle = Start position to end of rotation and returning to the start position. Stroke = 1/2 cycle
4. Pressure Rating for 41X and 42X is 500 psi max.

Capacity per Stroke ³ (IN ³)			
270° Rotation ²		90° Rotation ²	
411	4.52	412	2.75
421	8.50	422	5.50
431	17.0	N/A	N/A

Weights (LBS.)			
270° Rotation ²		90° Rotation ²	
411	2.5	412	2.5
421	3.3	422	3.5
431	6.0	N/A	N/A

How to Order: Turn-Dex 2-1/2" Bore

DRIVE
MODEL DIRECTION OPTIONS OPTIONS
413 - 2 - 200 - XXX
1 2 3 3

1

Model			
Model	Bore	Torque	Rotation
411	2-1/2"	87	270
412	2-1/2"	175	90
413	2-1/2"	87	180
414	2-1/2"	175	45
421	2-1/2"	175	270
422	2-1/2"	350	90
423	2-1/2"	175	180
424	2-1/2"	350	45
431	2-1/2"	350	270
433	2-1/2"	350	180

2

Drive Direction	
Based on shaft end view and inlets at 12 O'Clock	
1	Clockwise
2	Counter-clockwise

3

Options	
Additional options available on pg. 9	
Option #	Description
000	No Options
100	Front Flange
101	Rear Flange
200	Side Angle Brackets, Mounting Surface 3 & 7
201	Side Angle Brackets, Mounting Surface 2 & 6
202	Side Angle Brackets, Mounting Surface 4 & 8
203	Side Angle Brackets, Mounting Surface 1 & 5
800	Side Mounts, Sides 1 & 5
801	Side Mounts, Sides 2 & 6
803	Side Mounts, Sides 4 & 8
804	Side Mounts, Sides 2, 4, 6 & 8
806	Side Mounts, Sides 6 & 8
807	Side Mounts, Sides 2 & 4
810	No Side Mounts
900	Cap End
Cap Sensor Options (See pg. 13)	
A00	Sensor System – No Sensors
A05	Sensor System – 2 Sourcing Sensors
A08	Sensor System – 2 Sinking Sensors
A02	Sensor System – 2 Reed Sensors
A25	Sensor System – 2 Sourcing Sensors*
A28	Sensor System – 2 Sinking Sensors*
A22	Sensor System – 2 Reed Sensors*

*NOTE: See page 13 for Lead Type variation

Dimensional Data: Turn-Dex 2-1/2" Bore

Basic Dimensions

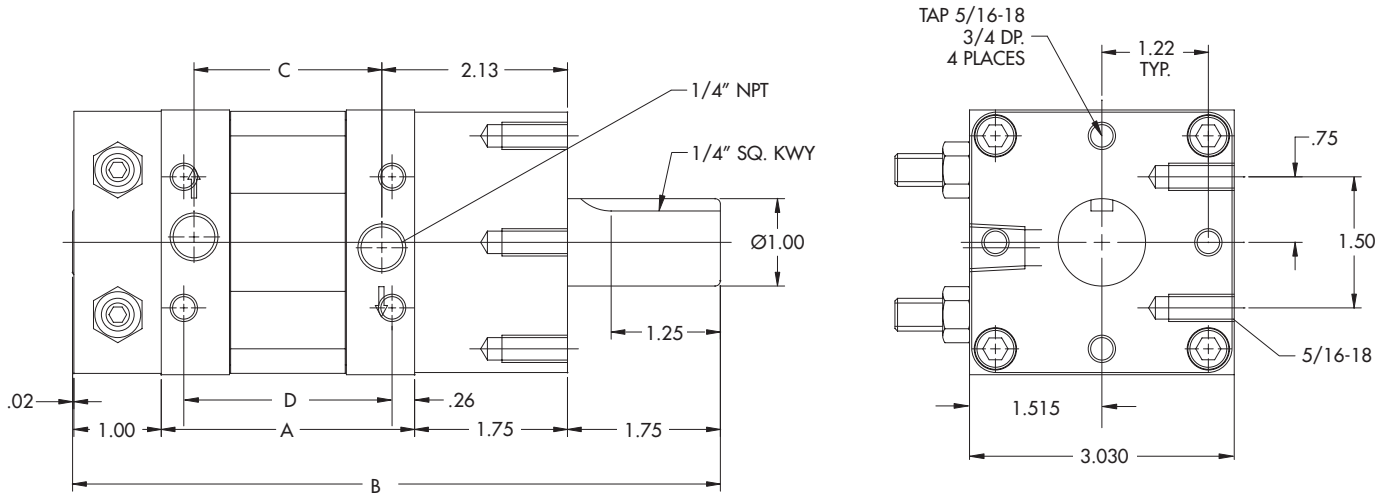

Dimensional Specifications

Actuator	A	B	C	D
41X	2.90	7.40	2.15	2.38
42X	4.40	8.90	3.64	3.88
43X	7.42	11.92	6.67	6.91
44X	10.38	14.88	9.63	9.86

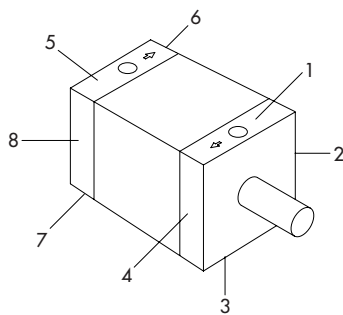

Port & Mounting Position References

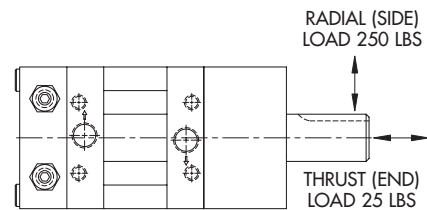

Shaft Load Capacity

Adjustable Stroke Control (ASC)

Standard on all Turn-Dex models, the Adjustable Stroke Control (ASC) allows an actuator to be adjusted to the exact rotational stroke desired. The ASC consists of a shaft mounted steel cam, enclosed in a housing with adjustment screws (see method of operation below). Turning the adjustment screws either extends or limits the amount of rotation. The ends of the adjustment screws impact the cam providing a positive and repeatable end of rotation stop. The ASC option is often specified for applications where the stroke required is not within the rotational tolerance. The standard rotational stroke tolerance of an actuator is $+4^\circ / -0^\circ$. (i.e.: A 90° actuator without ASC will have a rotation of 90° - 94° . With the addition of the ASC option a precise 90° rotation is attainable.)



Option #	Description
402	ASC Cap End, Position 6
404	ASC Cap End, Position 7
406	ASC Cap End, Position 8

NOTE: The Thrust Protection Option (see pg 12) is integrated into the ASC Housing.

Actuator Rotation	Adjusting Range
90°	0-90 degrees
180°	90-180 degrees
270°	90-270 degrees

NOTE: Rotations greater than 180° are not fully adjustable with a standard 2 screw adjustable stroke control. Consult factory for greater adjustment range.

Adjustable Stroke Control (ASC) Dimension				
MODEL/Bore	(A=max) in.	(B) in.	(C) in. Sq.	(D) in.
Turn-Dex 1-1/4"	1.500	0.656	1.63	.13"
Turn-Dex 2-1/2"	3.250	1.000	3.03	.10"

Position Reference Drawing

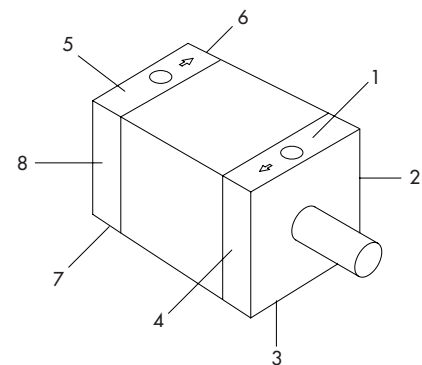

NOTE: Specify the position to be tapped for adjustment screws. Example: Option 407 would call out position 4 as the adjustment screw location, as depicted in the drawing above.

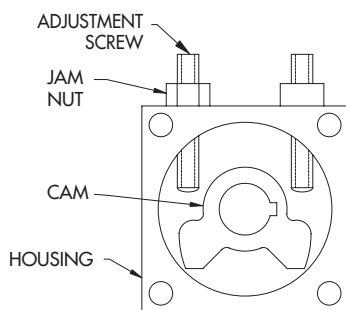

Method of Operation

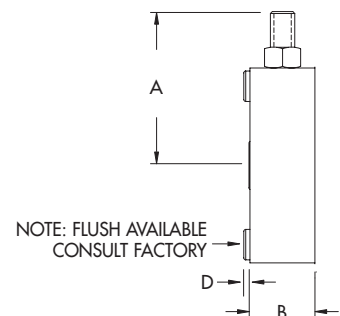
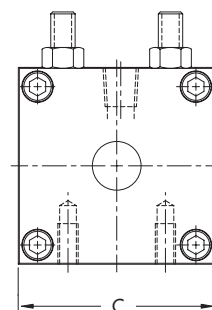

Dimensional Data

Turn-Dex Options – Flange Mount

Turn-Dex 1-1/4" Bore

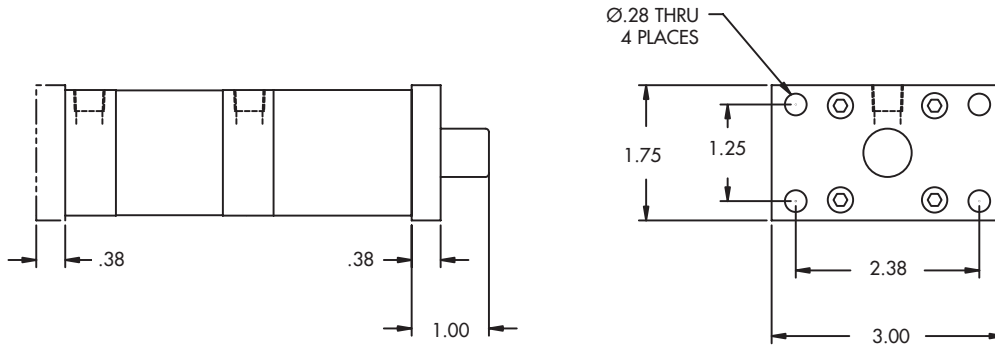

NOTE: ASC is standard on all Turn-Dex models but omitted for clarity.
Side Mounts surface 3 & 7 are standard, but are not shown for clarity.
Please refer to page 4 for dimensional information.

Turn-Dex 2-1/2" Bore

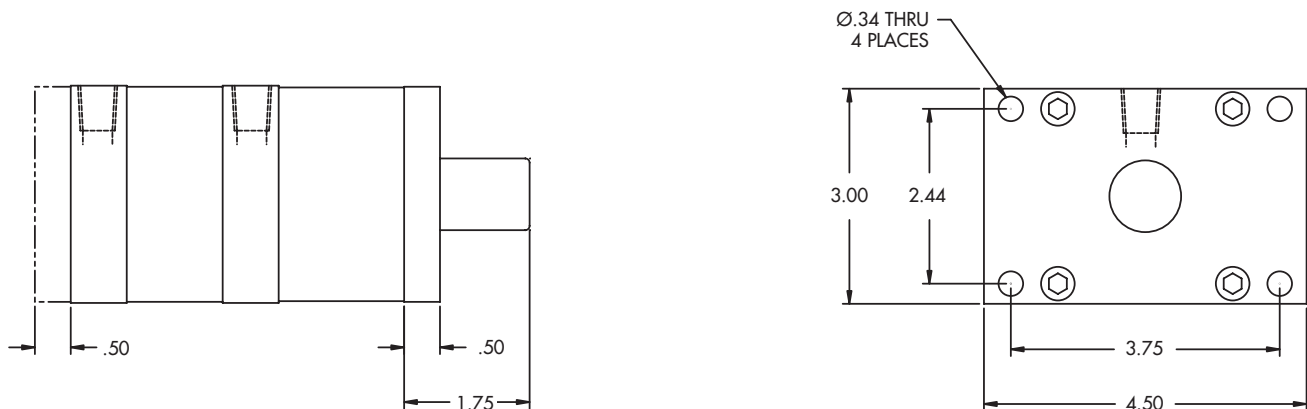

NOTE: ASC is standard on all Turn-Dex models but omitted for clarity.
Side Mounts surface 3 & 7 are standard, but are not shown for clarity.
Please refer to page 7 for dimensional information.

Option#	Description
100	Front Flange
101	Rear Flange

NOTE: The Flange Mount option and Adjustable Stroke Control option may not be ordered on the same end of a unit. Consult factory for additional flange options.

Turn-Dex Options - Side Angle Mounts

Option #	Description
200	Side Angle Brackets, Mounting Surface 3 & 7
201	Side Angle Brackets, Mounting Surface 2 & 6
202	Side Angle Brackets, Mounting Surface 4 & 8
203	Side Angle Brackets, Mounting Surface 1 & 5

NOTE: Specify the surface to be used for mounting. Example: Option 200 would call out surface 3 & 7 as the mounting surface, Option 201 would call out surface 2 & 6 as the mounting surface.

(2-1/2" Bore Only)

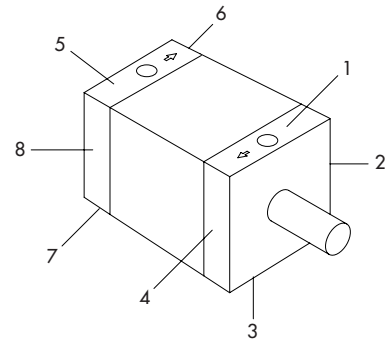

Mounting Surface Reference Drawing

Turn-Dex 2-1/2" Bore

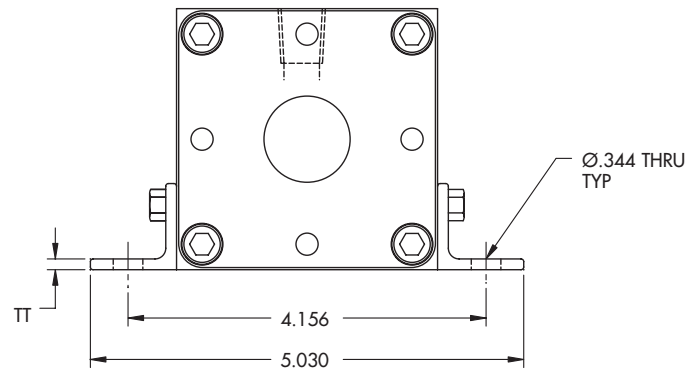
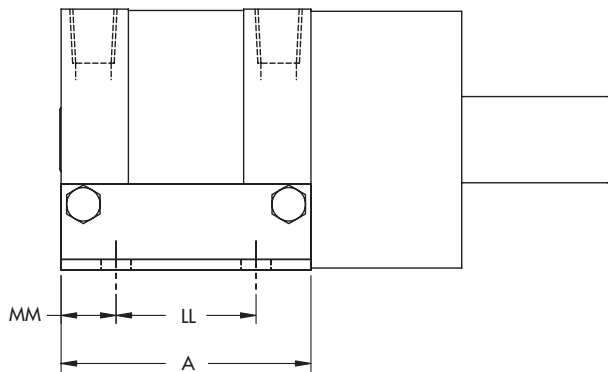

Option 200
Shown in Drawing

NOTE: ASC is standard on all Turn-Dex models but omitted for clarity. Please refer to page 7 for dimensional information.

Turn-Dex Model	A	LL	MM	TT
41X	2.90	1.625	.638	.125
42X	4.40	3.000	.694	.125
43X	7.42	6.000	.712	.119
44X	10.38	9.125	.626	.188

Turn-Dex Options - Side Mounts

Option #	Description
Side Mounts, Sides 3 & 7 Standard on all Mounts	
800	Side Mounts, Sides 1 & 5
801	Side Mounts, Sides 2 & 6
803	Side Mounts, Sides 4 & 8
804	Side Mounts, Sides 2, 4, 6 & 8
806	Side Mounts, Sides 6 & 8
807	Side Mounts, Sides 2 & 4
810	No Bottom Mounts

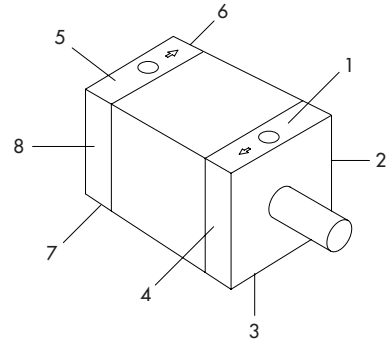

Position Reference Drawing

NOTE:

- Specify the side to be used for mounting. Example: Option 804 would call out sides 2, 4, 6 & 8 as the mounting surfaces, as depicted in the drawings below. Mount sides 3 & 7 are standard on all models but are not shown for clarity.
- ASC is standard on all Turn-Dex models but omitted for clarity. Please refer to page 8 for dimensional information.

Turn-Dex 1-1/4" Bore

Comp-Act Models	D
31X	1.00
32X	1.50
33X	2.00
34X	2.50
36X	4.05

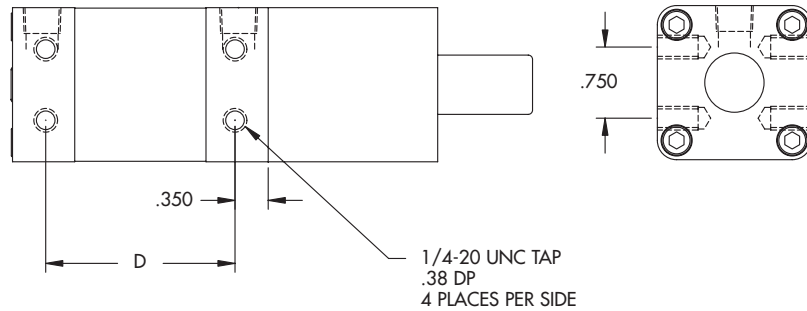

NOTE:

- Mounts surface 3 & 7 are standard, but are not shown for clarity. Standard Bottom Mount dimensions shown on page 4.
- ASC is standard on all Turn-Dex models but omitted for clarity. Please refer to page 8 for dimensional information.

Turn-Dex 2-1/2" Bore

Turn-Act Models	D
41X	2.38
42X	3.88
43X	6.91
44X	9.86

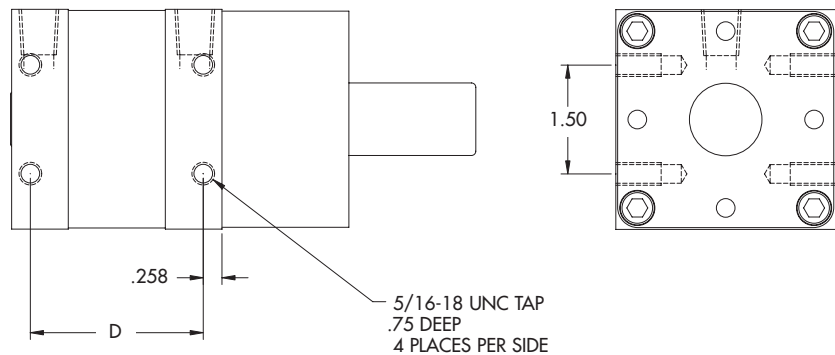

NOTE:

- Mounts surface 3 & 7 are standard, but are not shown for clarity. Standard Bottom Mount dimensions shown on page 7.
- Center drill omitted from shaft details for clarity.
- ASC is standard on all Turn-Dex models but omitted for clarity. Please refer to page 8 for dimensional information.

Turn-Dex Options - Thrust Protection

Excessive thrust load will cause premature seal wear and shorten actuator cycle life (See chart below). Applications that produce high linear/thrust loads, such as when the shaft is vertical, with the load set on or hanging from the shaft may require the Thrust Protection option.

This option consists of a series of internal thrust bearings and a shaft collar enclosed in a machined aluminum housing. This system effectively isolates the load from the actuator vane, permitting higher thrust load limits (See chart).

NOTE: The Adjustable Stroke Control (ASC) Option is integrated into the Thrust Protection Housing.



TURN-DEX SERIES ACTUATOR WITH OPTIONAL THRUST PROTECTION.

Option #	Position
901	Rod End

APPLICATION CONSIDERATIONS

Overrun:

The output shaft can be manually rotated only in its drive direction. Large loads may coast after the actuator has stopped. The output shaft cannot be reverse rotated. Forcing it backwards could damage the Turn-Dex.

Accurate & Repeatable Positioning:

Due to the overrun nature of the clutch, external stops, brakes, roller and detents or shot-pins are required for accurate and repeatable positioning.

Special Options:

Customized units to fit your specific application needs. Modifications include special shafting, special mounts, clutch housings with shot-pin cylinders, disc brakes and thrust protection. Consult factory for additional information.

Turn-Dex Options - Cap Sensor Systems

Turn-Dex Actuators are available with electronic position sensing sensors. The sensors have LED lamps that light when in sensing position. If adjusted for end of stroke indication, the LED will remain lit as long as the stroke position is maintained. A small shaft mounted magnet in the sensor housing operates the sensors (see drawings).



Sensor System with 8mm Quick Disconnect



Sensor System with 9 ft. Leads

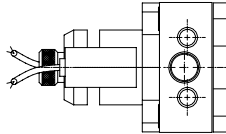

Turn-Dex 1-1/4" Bore Sensors

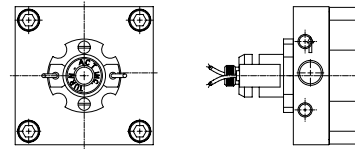
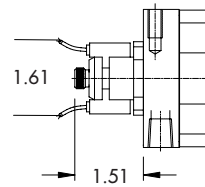

Turn-Dex 2-1/2" Bore Sensors

SENSOR PACKAGE (CAP END)							
Includes a <u>Cap End</u> Mounted Sensor Ready Housing							
Option #	Switch Type	Function	Lead Type	Sensing Voltage	Sensing Current	Sensing Power	Max. Voltage Drop
A00	Sensor Ready No Sensors	-	-	-	-	-	-
A05	PNP/Sourcing	Normally Open Output	22 gauge	6-24 VDC	0.5 Amp Max	N/A	0.5 Volts
A08	NPN/Sinking	Normally Open Output	22 gauge	6-24 VDC	0.5 Amp Max	N/A	0.5 Volts
A02	AC/DC Reed	SPST Normally Open	22 gauge	5-120 VDC/VAC 50/60 Hz	0.5 Amp Max 0.005 Amp min.	10 watts Max	3.5 Volts
A25	PNP/Sourcing	Normally Open Output	8mm Type - B QD	6-24VDC	0.5 Amp Max	N/A	0.5 Volts
A28	NPN/Sinking	Normally Open Output	8mm Type - B QD	6-24VDC	0.5 Amp Max	N/A	0.5 Volts
A22	AC/DC Reed	SPST Normally Open	8mm Type - B QD	5-120 VDC/VAC 50/60 Hz	0.5 Amp Max 0.005 Amp min.	10 watts Max	3.5 Volts

Caution: Sensors will be permanently damaged if operated without a load. Consult factory if lead length is lead length will exceed 20 ft.

NOTE: 2 sensors per option.

Turn-Dex Options - Trantorque®

Trantorque

Trantorque keyless shaft couplings eliminates:

- The need for keys, keyways and setscrews.
- Simplifies synchronization.
- Allows for infinite radial adjustments.
- Mounts hubless devices.

The Trantorque coupling uses 2 opposing tapers that expand into the OD and contract on the ID to attach and hold shaft loads.

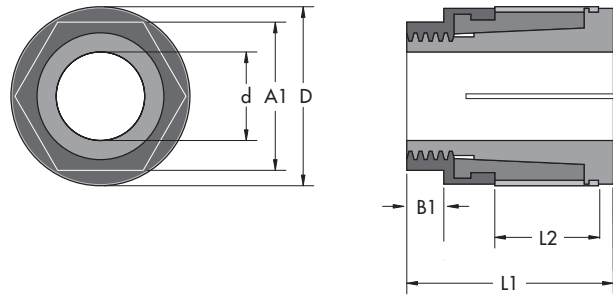

Non-Traversing

Style	Trantorque Series	Part #	Actuator Shaft Diameter (d)	Component Bore (D)	Max. Transmissible		Dimensions						
					Tq.	Thrust	L1	L2	A1	A2	B1	B2	
Non-Traversing	Imperial Series	Turn-Dex 1-1/4"	6980120	5/8"	1-1/2"	1225 in lbs.	2310 lbs.	1-21/32"	11/16"	1-1/4"	1-1/2"	5/16"	5/16"
		Turn-Dex 2-1/2"	6980240	1"	1-3/4"	2450 in lbs.	4620 lbs.	2-1/32"	13/16"	1-1/2"	1-3/4"	7/16"	3/8"

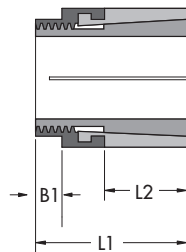
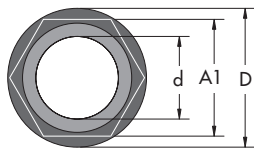

Mini series

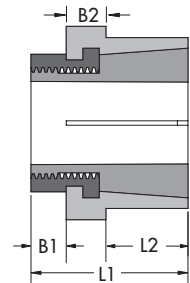
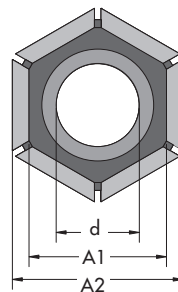

GT series

Style	Trantorque Series	Part #	Actuator Shaft Diameter (d)	Component Bore (D)	Max. Transmissible		Dimensions						
					Tq.	Thrust	L1	L2	A1	A2	B1	B2	
Standard Models	Imperial Series	Turn-Dex 1-1/4"	6980120	5/8"	1-1/2"	1750 in lbs.	3300 lbs.	1-1/2"	3/4"	1-1/4"	1-1/2"	5/16"	5/16"
		Turn-Dex 2-1/2"	6980240	1"	1-3/4"	3500 in lbs.	6600 lbs.	1-7/8"	7/8"	1-1/2"	1-3/4"	7/16"	3/8"

Style	Trantorque Series	Part #	Actuator Shaft Diameter (d)	Component Bore (D)	Max. Transmissible		Dimensions						
					Tq.	Thrust	L1	L2	A1	A2	B1	B2	
Stainless Models	Imperial Series	Turn-Dex 1-1/4"	6980120	5/8"	1-1/2"	525 in lbs.	990 lbs.	1-1/2"	3/4"	1-1/4"	1-1/2"	5/16"	5/16"
		Turn-Dex 2-1/2"	6980240	1"	1-3/4"	1050 in lbs.	1980 lbs.	1-7/8"	7/8"	1-1/2"	1-3/4"	7/16"	3/8"

Turn-Dex Options - Hub Adapter

This option provides an alternative to the conventional output shaft. The Hub Adapter option allows for easy mounting of grippers, tooling, actuators, cylinders and other end effectors that require a flat mounting surface.

The Hub is manufactured of aluminum with 4 counter bored through holes on one side and tapped holes on other. Trantorque (see Trantorque section) is used in mounting of the Hub Adapter to the actuator shaft. This attachment method provides infinite hub/hole orientation.

Option #	Description
M10	W/Carbon Steel Trantorque
M20	W/Stainless Steel Trantorque

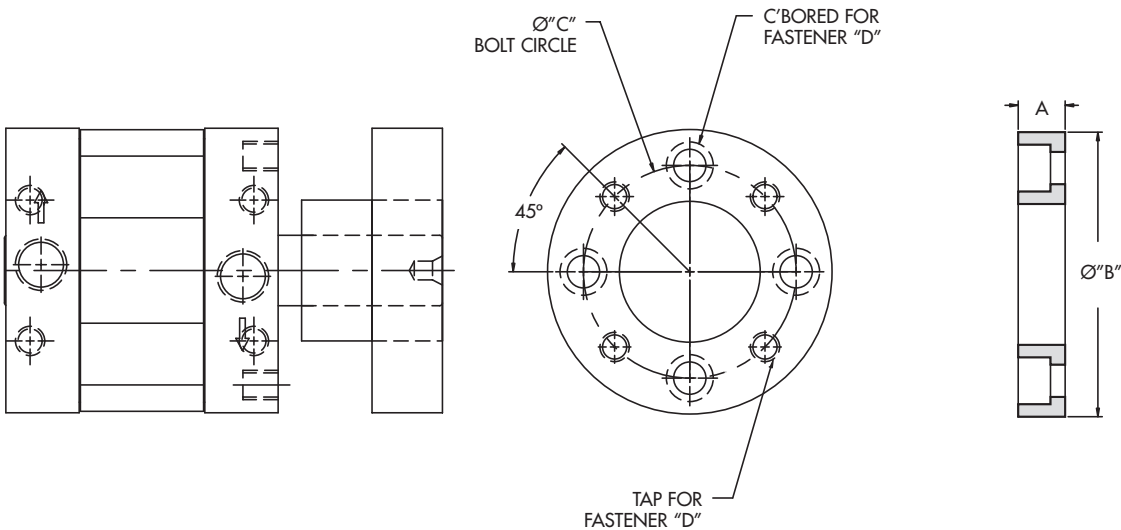

Trantorque with Hub Adapter

Hub Adapter Dimensions	Turn-Dex 1-1/4" Bore	Turn-Dex 2-1/2" Bore
A	0.438"	0.750"
B	1.563"	2.500"
C	1.156"	2.000"
D	#10-24	1/4-20

NOTE: Contact Factory for other hub diameters, bolt hole patterns, etc.

Special Conditions and Limited Warranty

Determination of the suitability of any information or product for the application contemplated by any user or the manner of that use is the sole responsibility of the user.

Compact Automation Products, LLC reserves the right to improve or change designs without notice.

All orders are subject to acceptance by the factory sales department.

Compact Automation Products, LLC agrees to repair or replace to the original purchaser any standard parts or products for a period of 12 months from date of shipment which Compact Automation Products, LLC determines upon inspection to be defective in workmanship or material. Wear components including but not limited to seals and bearings are excluded from this warranty.

Under no circumstance may merchandise be returned without written authorization from the factory.

This warranty is void in the event the product has been tampered with, altered, or serviced by unauthorized personnel.

Compact Automation Products, LLC's total responsibility for any claims, damages, losses or liabilities related to the product covered thereunder shall not exceed the purchase price of such product. In no event shall Compact Automation Products, LLC be liable for any special, indirect, incidental or consequential damages of any character, including but not limited to loss of use of productive facilities or equipment, lost profit, property damage, transportation, installation or removal or lost production whether suffered by purchaser or third party. Compact Automation Products, LLC disclaims all liability for any and all cost, claims demands, charges, expenses, and other damages, either direct or indirect, incident to all property damage arising out of any cause of action based on strict liability. This warranty gives you specific legal rights and you may have other rights, which vary from state to state.

Answer Engineering
COMPACT
AUTOMATION PRODUCTS LLC
An IMC Company

Compact Automation Products, LLC
105 Commerce Way
Westminster, SC 29693
USA
Tel: 864.647.9521
Fax: 864.647.9574
www.compactautomation.com

Just imagine...
How Compact Automation Product's
Answer Engineering can work for you!